



acer

acer *Education*

### **Acer Interactive Whiteboard**

Do you remember the slate blackboards, the colored chalks and the eraser that left your hands white? Well, now they are just a memory. Acer Interactive Whiteboard, connected to a personal computer and a projector can revolutionize school lessons.

With Acer Interactive Whiteboard the path to knowledge is full of incredible sound and colour, shape and movement, and any lessons becomes an interactive learning experience that is engaging and dynamic.

A large 77-inch interactive display, combining the features of a blackboard with the power of a computer and a front projection is the Acer solution for modern and innovative didactics.

By using a special pen, the large screen becomes an interactive display. With the pen you can select one of the 16 shortcuts to launch applications, open and close windows, draw or write notes on the projected image or on a blank screen.

## IWB-770 Product Specification

### FEATURES

These specifications are applicable only to Acer IWB-770

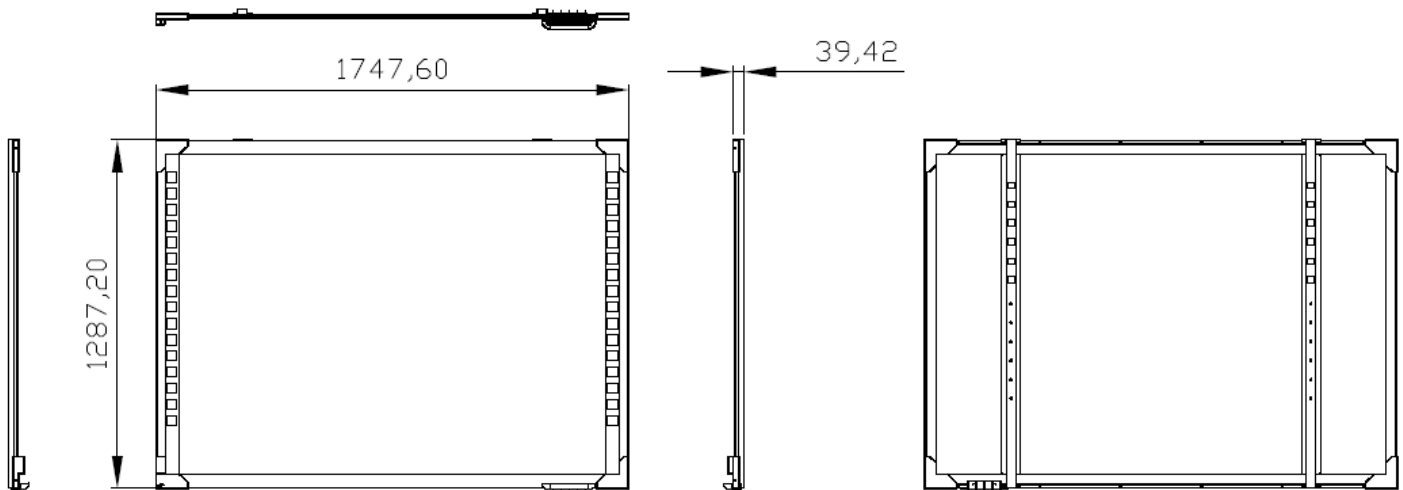















Product Drawing <1>

## Product specifications

Whiteboard			
<b>Diagonal (Interactive white board)</b>	77"	<b>Resolution</b>	600 Lpi above (37330*27870)
<b>Dimension</b>	1747*1287mm	<b>Pressure level</b>	1024 levels
<b>Active Area</b>	1580*1180 mm	<b>Reporter Rate</b>	200 rps
<b>Weight</b>	26.5 kg	<b>Hotkey</b>	16 * 2
<b>Reading height</b>	12 mm	<b>Tilt angle</b>	45°
<b>Technology</b>	electromagnetic	<b>Pen tray / holder</b>	yes
<b>Power Supply</b>	USB Vbus (+5V)	<b>Bundle Pen</b>	L7 Pen*2
<b>Power consumption</b>	80mA (400mW) +- 10%	<b>Support OS</b>	Windows 2000/XP/Vista
<b>Connection Interface</b>	USB 1.1 (12Mbps Full Speed)	<b>Standards, etc.</b>	FCC Class B, CE,BSMI
<b>USB Cable</b>	5m	<b>Warranty</b>	tbd

Pen (L7)			
<b>Pen Tip</b>	Mouse left button, with pressure information	<b>Tip Travel</b>	2 mm max.
<b>Lower Barrel Button</b>	Default as mouse right button (programmable)	<b>Tip Switch ON Load</b>	Less than 38 g
<b>Upper Barrel Button</b>	Barrel 2 (programmable)	<b>Battery</b>	AAA x1

## Hotkey Functions

ITEM	Description	ICON
1		
2	<b>Color Block:</b> You can use the coloured pencil icons to choose the colour you want to write with.	
3		
4		
5	<b>Pen Tool / Cursor:</b> There are three pen types, pen, brush and marker. You can use any of them as your writing tool. If you want to indicate things, you can click on “cursor” icon to change it. Click on the cursor icon to revert to cursor mode and indicate things. <b>Note: Applying a different pressure on the whiteboard when you are using the pen tool doesn't change the line width, but it does when you are using the brush tool.</b>	
6		
7		
8		<b>Eraser Tool:</b> You can select “delete all” or “erase” to correct what you've written. <b>Note: When using “erase”, you can choose to erase only one line you've drawn or select an area to delete.</b>
9		
10	<b>Point Outline:</b> You can choose from two width of point outlines.	
11		
12	<b>Slide films / Whiteboard:</b> These two icons are active when Microsoft PowerPoint is running and preparing to play a slide show. Using these icons you can toggle between two screens to write or make notes.	
13		
14	<b>Previous / Next:</b> These two icons are active only when Microsoft PowerPoint is running. They are useful to navigate slide shows.	
15		
16	<b>Exit:</b> Click on this icon and Power Presenter RE will be closed.	

## Electrical Characteristics

Power	Power Source	USB Vbus (+5V)
	Power Consumption	80mA (400mW) +- 10%

## Mechanical Characteristics

1	Weight	25.5 + -1.5 kg
2	Dimensions	1747*1287mm
3	USB Cable	5m

### Wall-Mounting Setup Method

**CAUTION: Keep the wall strength in mind when installing. Only use this product after confirming that it is securely attached and will not fall. Furthermore, be sure to install using a wall-mounting bracket capable of supporting a weight of at least 50 kg.** Install the wall-mounting brackets.

Determine the height at which the board will be installed, and install the wall-mounting brackets on the wall at the positions shown in the following diagram below. The wall-mounting brackets are provided with the Whiteboard.

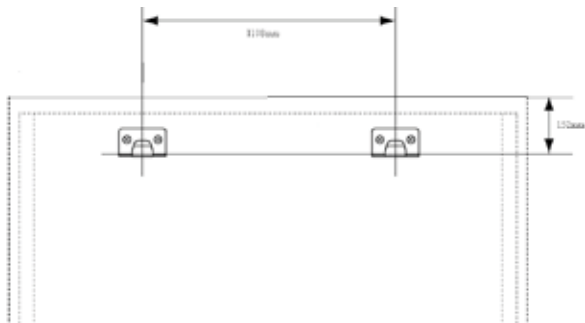

Attach the wall-mounting brackets to the top square holes (both sides) of the stays on the back of the board.

## Reliability

No	Test Item	Test condition
1	Temp/Humi Cycling operating test	20%~80%RH, 0~40 °C, During 4hrs, 6 Cycles
2	Temp/Humi Cycling storage test	20%~95%RH (Non-condensing), -20~50 °C , During 4hrs, 6 Cycles
3	Shock test (non-operating)	Half-sine wave: 60G, 11ms ,3 shock / face, 4 faces
4	Vibration test (packing)	Random vibration : 50~500 Hz , 0.015G <sup>2</sup> / Hz , 2.16 Grms , 1 hr/axis, X,Y,Z AXIS
5	Drop test (non-packing)	N/A
6	Drop test (packing)	50.8 cm, 1 corner, 3 edges, 6 faces, 3times
7	Button Test	N/A
8	Life Test	MTBF>6000 hrs

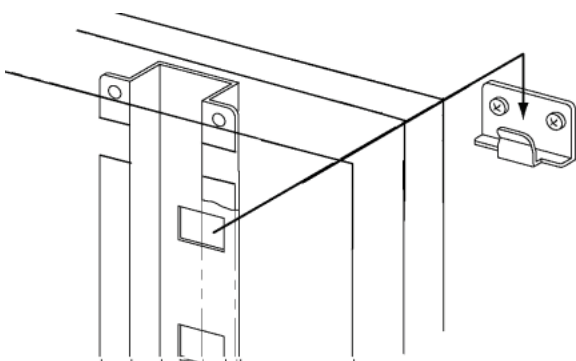

Rason Global Services Ltd  
 Unit 20 Morebam Complex, by NNPC, along  
 American Int' School, Durumi FCT,  
 Abuja, Nigeria  
 +2348038575356 | info@rasonglobal.com  
<https://rasonglobal.com>